



728 series MULTI-VANE STAINLESS STEEL AIR MOTORS



Stainless Steel housing renders 728 series ideal for clean applications such as food processing, chemical and pharmaceutical industries and wherever corrosive environment is present.

The right torque at right speed

High power to weight ratio, easy installation, portability, minimum maintenance and simple control are other features making INGERSOLL-RAND air motors an attractive solution for a number of industrial applications.

Many users will find that they can substitute air motors from other manufacturers with **728** series.

The reasons to choose a **728** series air motor:

Variable Speed

- Controllable over a wide speed range. When an increase in load lowers the speed, the torque increases.

Explosion-Proof

- Perfect in applications in hazardous or hostile environments

Instantly Reversible

- Easy reversing using a directional control valve.

Cool Running

- Cool and spark-free operation.

Compact and Portable

- Air motors can work in any position and are easy to install.

Minimum Maintenance

- Simple design and construction results in low maintenance and less down time

Will Not Burn Out

- Will not overheat or sustain any other type of damage.

No-shock Starts

- Accept repeated starting and stopping without limitation.

Self-sealing vanes

- Vanes automatically take up their own wear

Stainless steel housing

- Ideal for food and chemical industries. Withstand corrosive environments.

Operate in all positions

- Air motors are easy to install and can work in any position providing adequate airline lubrication.

Mounting Flexibility

- Simple control methods; Torque, speed and direction can be changed using simple controls.

Long Life Accessories

- Resistant to moisture, dust and heat

Output Power vs Speed

- Output power inherently adjusts to match the applied load

Torque vs Speed (Self Adjustable)

- When increased load lowers the speed, torque increases

Air Consumption vs Speed

- Air consumption increase only when speed or air pressure increase.

Mounting flexibility

- Compact in their design the **728** series motors provide ease of installation where space is limited

728 Series Stainless Steel Housing Air Motors

Air Motors are a compact, lightweight and safe source of power that is a perfect alternative to electric motors. Unlike electric motors, they are ideal solution for the applications with frequent stalling, reversing and overloading. No heat built up and spark-free operation make air motors suitable for applications in hazardous areas. Minimal maintenance and simple control make them an attractive option for your industrial applications.

Applications

- Food industry
 - Pharmaceutical industry
 - Chemical industry
 - Mixing equipment
 - Conveyor drives
- Plastic industry
 - Strapping machines
 - Medical pump
 - Printing machinery
 - Punch Presses
- Paint, Ink, composite material, and Glue systems
 - And all applications in hazardous areas...

Non reversible models	Max Power		Speed @ max power	Starting Torque Nm	Stall Torque Nm	Air consump in l/s	Weight Kg	Length (A) mm
	HP	kW						
728RHR004BRM	0,44		1800	2,6	3,4	7,4	0,950	118
728RHR007BRM	0,44		1000	4,5	6	7,4	0,950	118
728RHR012BRM	0,44		550	8,7	11,3	7,4	1	135
728RHR017BRM	0,44		400	11,4	15,2	7,4	1	135
728RHR023BRM	0,44		300	15	20	7,4	1	135
728RHR031BRM	0,44		225	21	28	7,4	1	135
728RHR058BRM	0,44		120	38	50	7,4	1,2	157
728RHR077BRM	0,44		90	51	68	7,4	1,2	157
728RHR103BRM	0,44		68	67	90	7,4	1,2	175
728RHR254BRM	0,44		27	170	230	7,4	1,3	175
728RHR350BRM	0,44		20	230	306	7,4	1,3	175

Reversible models	Max Power		Speed @ max power	Starting Torque Nm	Stall Torque Nm	Air consump. in l/s	Weight Kg	Length (A) mm
	HP	kW						
728RVR004BRM	0,44		1800	2,6	3,4	7,4	0,950	118
728RVR007BRM	0,44		1000	4,5	6	7,4	0,950	118
728RVR012BRM	0,44		550	8,7	11,3	7,4	1	135
728RVR017BRM	0,44		400	11,4	15,2	7,4	1	135
728RVR023BRM	0,44		300	15	20	7,4	1	135
728RVR031BRM	0,44		225	21	28	7,4	1	135
728RVR058BRM	0,44		120	38	50	7,4	1,2	157
728RVR077BRM	0,44		90	51	68 ¹⁾	7,4	1,2	157
728RVR103BRM	0,44		68	67 ¹⁾	90 ¹⁾	7,4	1,2	175
728RVR254BRM	0,44		27	170 ¹⁾	230 ¹⁾	7,4	1,3	175
728RVR350BRM	0,44		20	230 ¹⁾	306 ¹⁾	7,4	1,3	175

Performance at 6 bars with open exhaust. Reversible air motors may also be supplied with brake.

¹⁾ Applications with those models must be limited to 60 Nm maximum.

PRODUCT IDENTIFICATION GUIDE

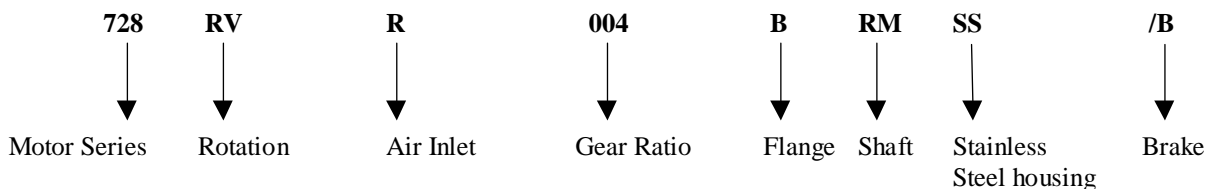

RV = Reversible Rotation

RH = Non Reversible Rotation (right hand as seen from the rear of the motor). Direction of rotation may easily be changed by inverting cylinder, without any additional parts.

004 = Gear ratio: 1 to 4

B = Round flange 4 hole face mounting as standard

RM = Round keyed shaft 11h6

SS = Stainless Steel spindle is available as Optional Equipment.

Performance Data

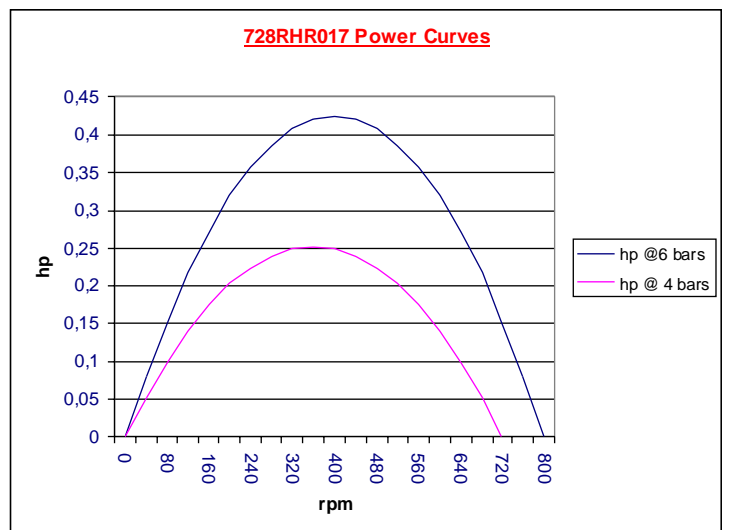
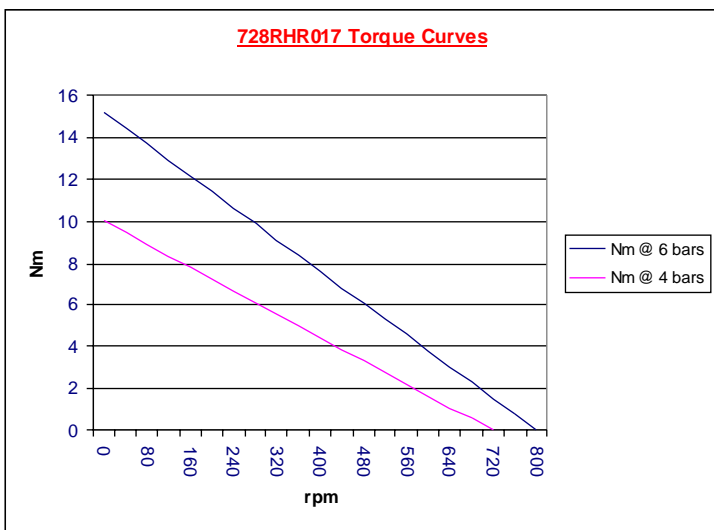
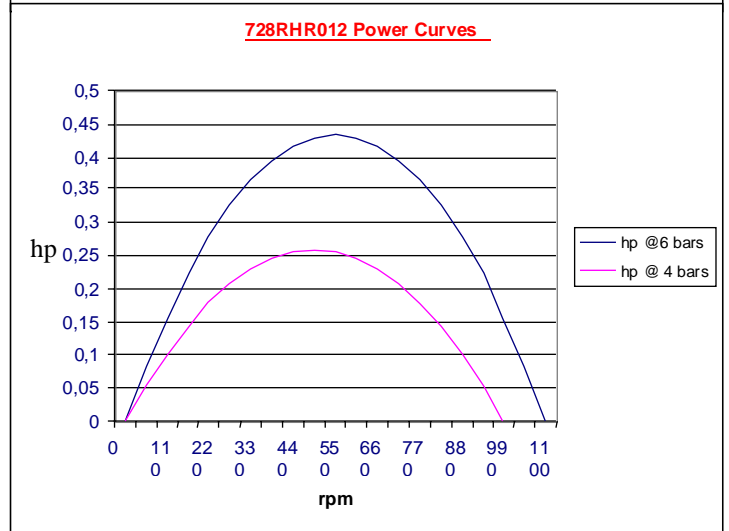
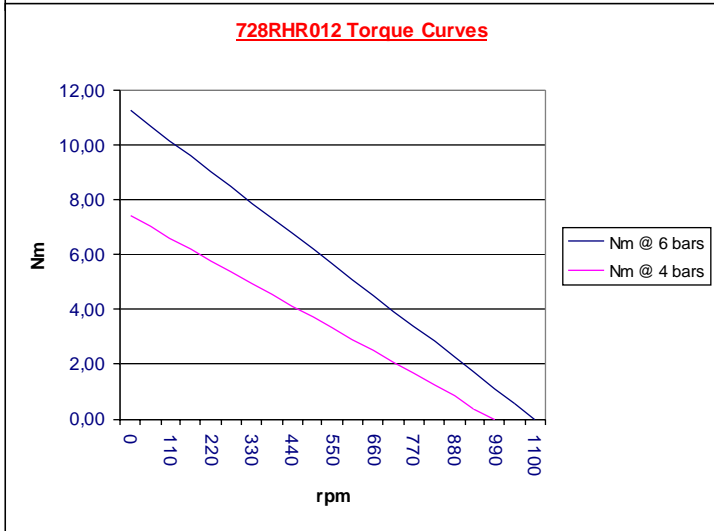
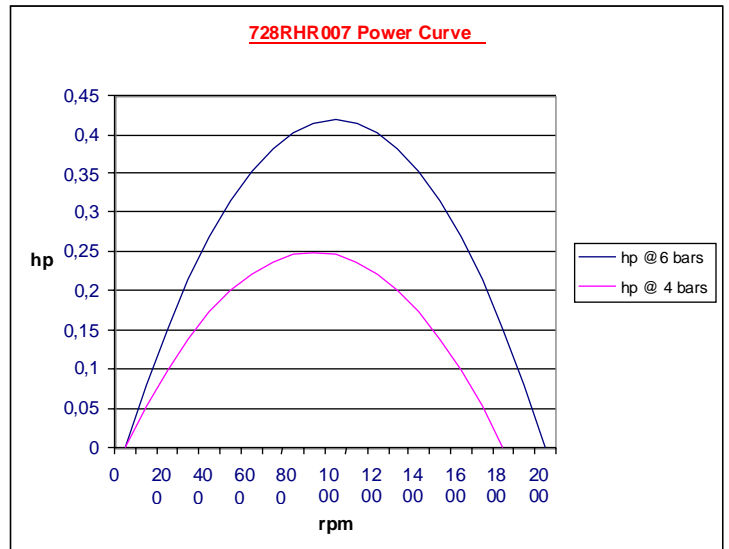
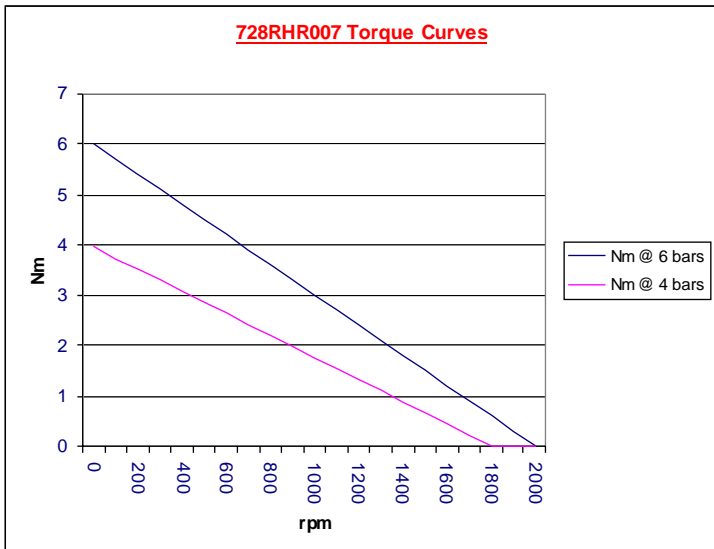

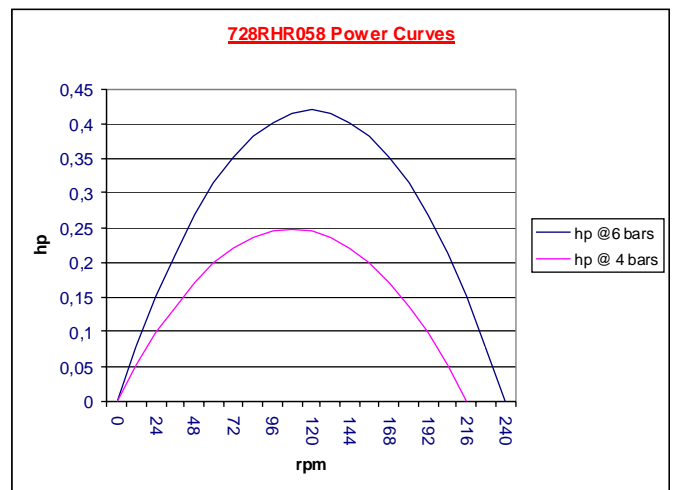
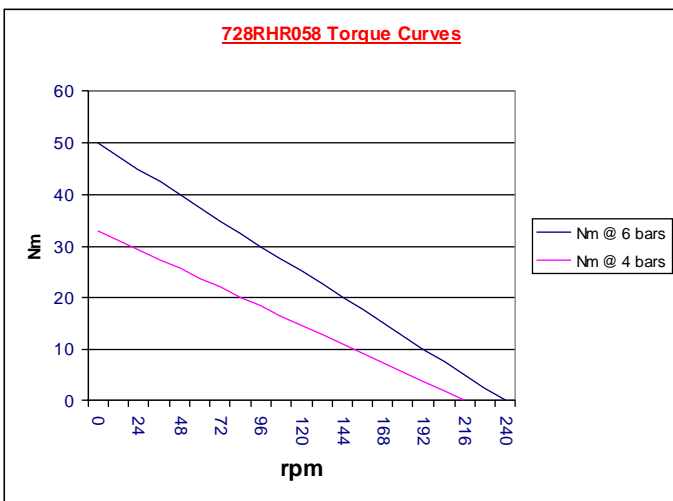
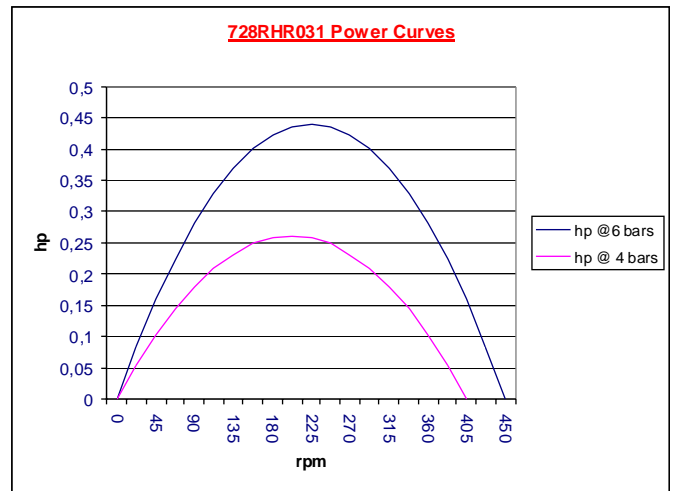
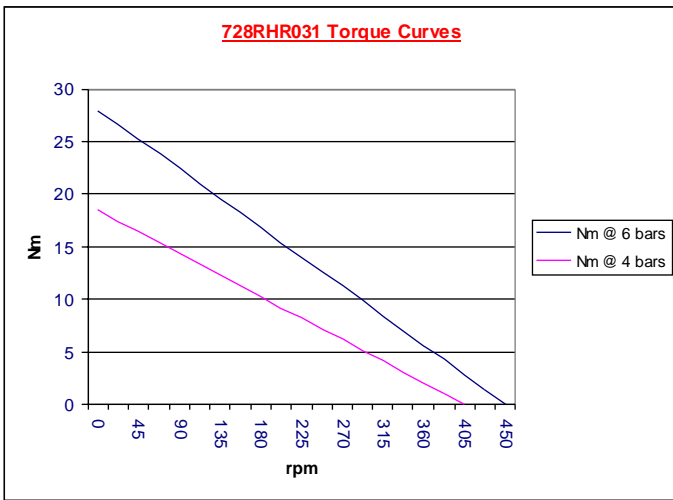
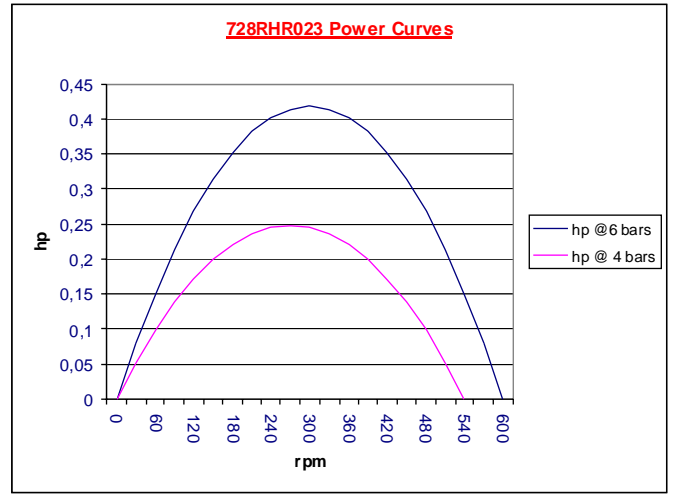
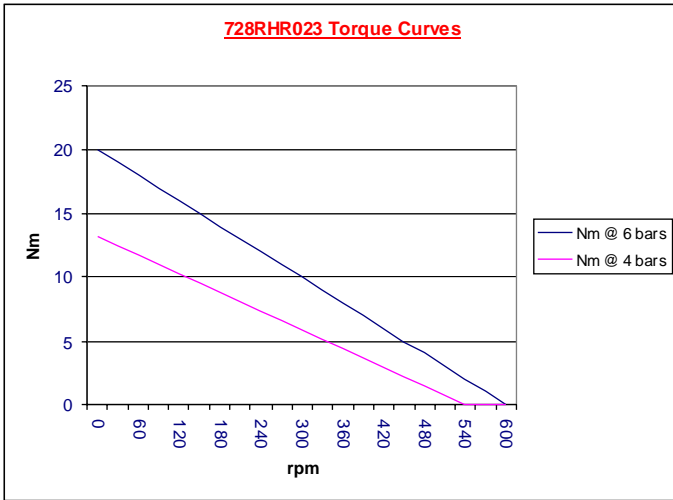

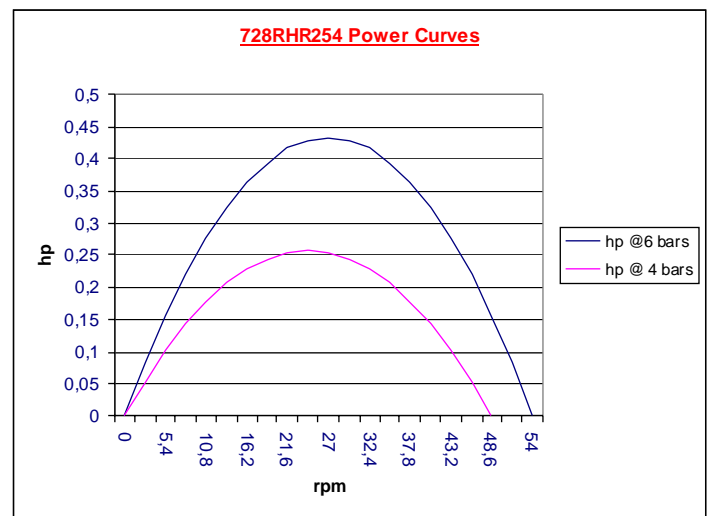
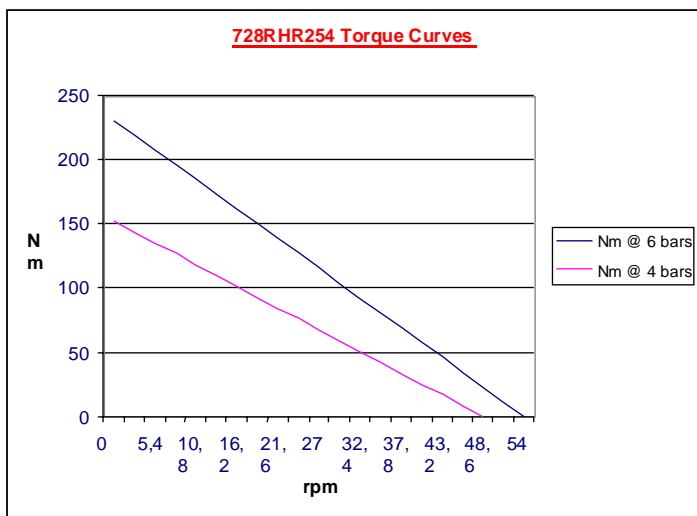
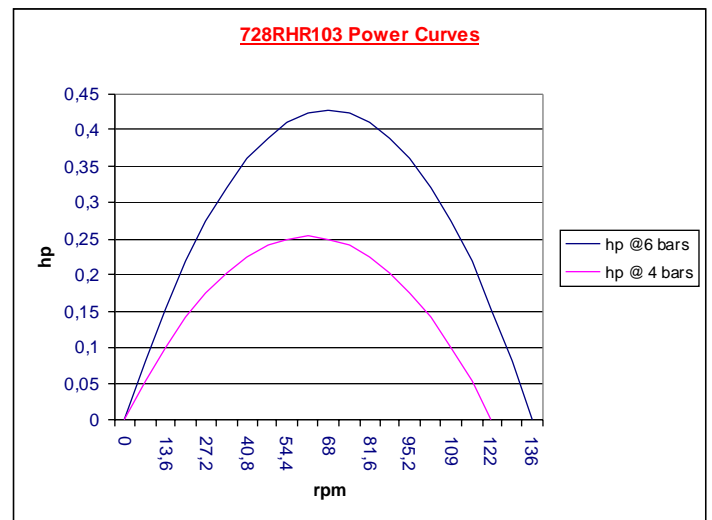
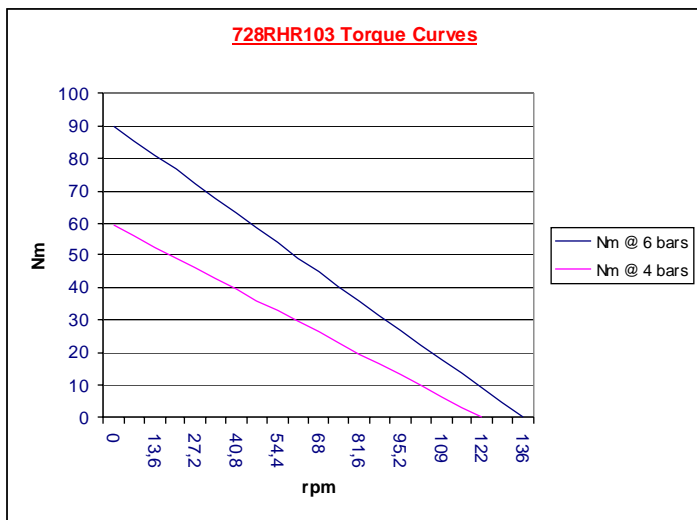
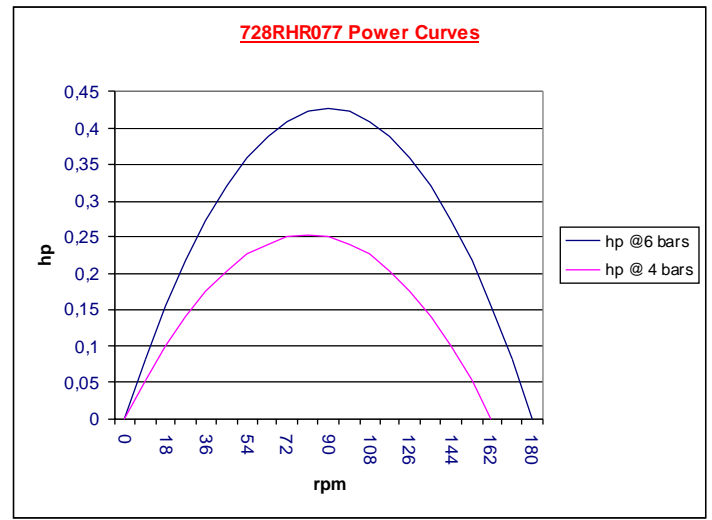
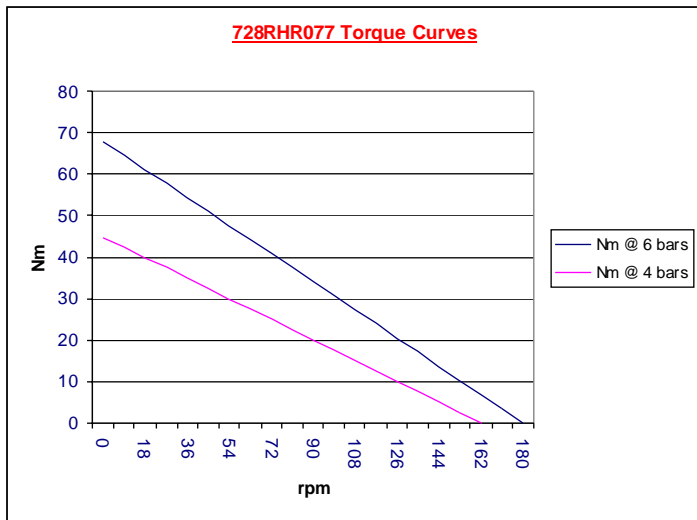

MODEL 728 DIMENSIONS

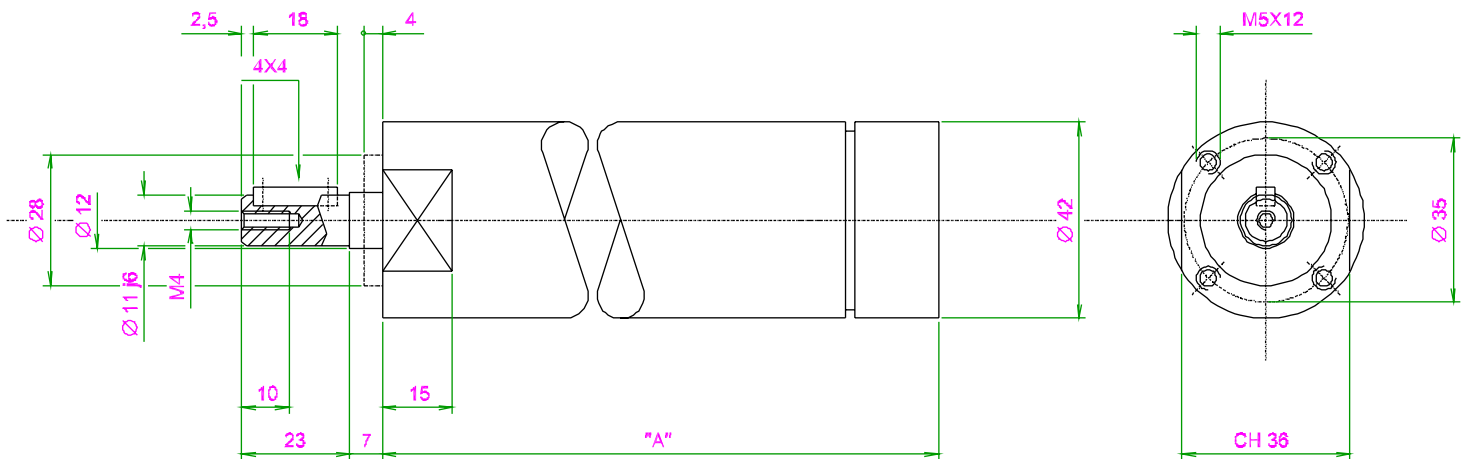

REVERSIBLE

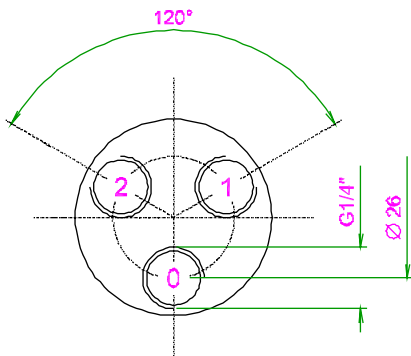

- 0 - EXHAUST
- 1 - Air inlet right hand rotation
- 2 - Air inlet left hand rotation

NON REVERSIBLE

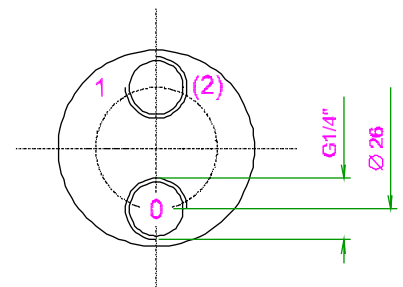

Hose sizes for up to 5 meters length.

Motor	Inlet Thread (BSP)	Exhaust Thread (BSP)	Inlet Hose Diameter (mm)	Exhaust Hose Diameter (mm)
728RHR	1/4	3/8	8	13
728RVR	1/4	1/4	8	13

- designed for the operating ranges from -30 to $+100^{\circ}\text{C}$
- 2 - 7 bar inlet pressures
- can be mounted in any position
- for use with compressed air or nitrogen
- inlet filter with 20 micron or better filtration is recommended.

Noise level at maximum power

MODEL	PRESSURE		
	4,3 Bar	5,3 Bar	6,3 Bar
728RHR - no muffler	88 dBa	90 dBa	94 dBa
728RVR - no muffler	88 dBa	90 dBa	94 dBa
728RHR with muffler	70 dBa	74 dBa	78 dBa
728RVR with muffler	70 dBa	74 dBa	78 dBa